

LIVE WITH
i ILVE

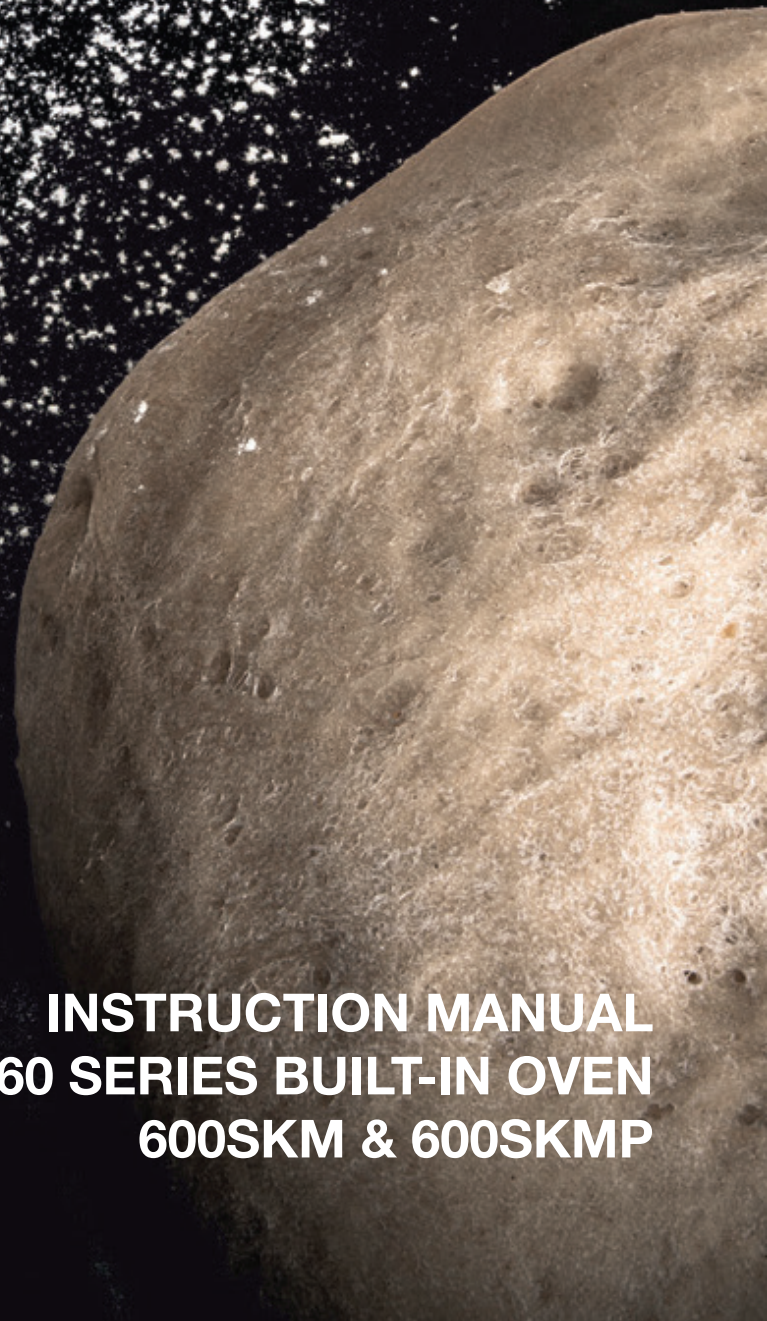

**INSTRUCTION MANUAL
FOR 60 SERIES BUILT-IN OVEN
600SKM & 600SKMP**



OPEN 24/7
ILVE ACCESSORIES ONLINE SHOP

For a wide range of coffee machines, pods, and other ILVE accessories at the click of a button shop.ilve.com.au

DEAR CUSTOMER,

We thank you and congratulate you on your choice. This new carefully designed product, manufactured with the highest quality materials, has been carefully tested to satisfy all your cooking demands. We would therefore request you to read and follow these easy instructions which will allow you to obtain excellent results right from the start.

IMPORTANT

The oven's data plate is accessible even with the oven fully installed. The plate is visible simply by opening the door. Always quote the details from it to identify the appliance when ordering spare parts.

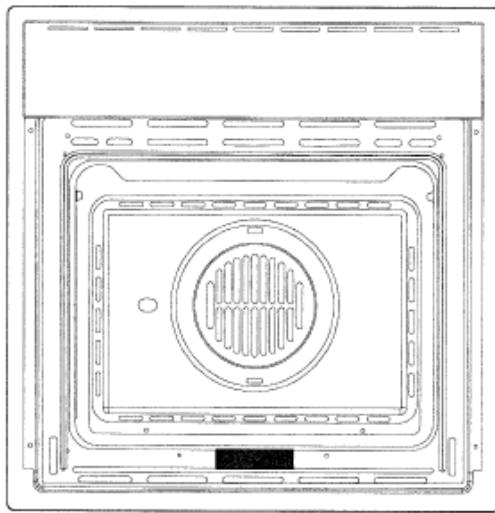

RESPECT FOR THE ENVIRONMENT

The documentation provided with this oven has been printed on chlorine free bleached paper or recycled paper to show respect for the environment. The packaging has also been designed to avoid environmental impact. Packaging material is ecological and can be re-used or recycled. By recycling the packaging, you will help save raw materials as well as reducing the bulk of domestic and industrial waste.

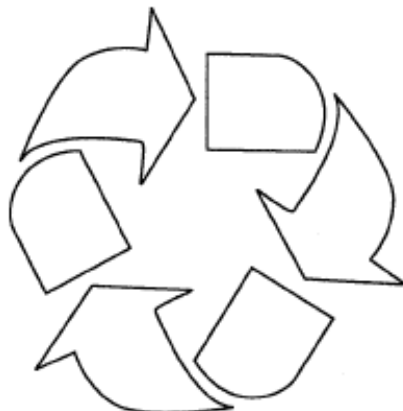

CONTENTS

First use	page 5
Self-cleaning panel	page 5
Control panel	page 6
Instructions for use:- conventional cooking	page 7
fan cooking	page 7
grill cooking	page 8
Thermostat	page 8
Cooking timer	page 9
Electronic timer	page 9
Light replacement	page 10
Removing the oven door	page 11

INSTALLATION INSTRUCTIONS

Flush fitting	page 11
Electrical connections	page 12
Warranty	page 14



THIS APPLIANCE IS CONCEIVED FOR DOMESTIC USE ONLY. THE MANUFACTURER SHALL NOT IN ANY WAY BE HELD RESPONSIBLE FOR WHATEVER INJURIES OR DAMAGES ARE CAUSED BY INCORRECT INSTALLATION OR BY UNSUITABLE, WRONG OR ABSURD USE.



THIS APPLIANCE IS NOT INTENDED FOR USE BY PERSONS (INCLUDING CHILDREN) WITH REDUCED PHYSICAL, SENSORY OR MENTAL CAPABILITIES, OR LACK OF EXPERIENCE AND KNOWLEDGE, UNLESS THEY HAVE BEEN GIVEN SUPERVISION OR INSTRUCTION CONCERNING USE OF THE APPLIANCE BY A PERSON RESPONSIBLE FOR THEIR SAFETY. CHILDREN SHOULD BE SUPERVISED TO ENSURE THAT THEY DO NOT PLAY WITH THE APPLIANCE.



CHILDREN SHOULD NOT CLEAN OR PERFORM MAINTENANCE WITHOUT SUPERVISION. DO NOT PLACE TIN FOIL, PANS OR SIMILAR IN CONTACT WITH THE INNER BASE OF THE OVEN TO COOK. THE HEATING ACTION OF THE LOWER RESISTANCE CAUSES THE LOWER PART OF THE OVEN TO OVERHEAT, LEADING TO DAMAGE AND EVEN SERIOUS CONSEQUENCES (FIRE RISK) ALSO TO THE UNIT IN WHICH THE OVEN IS INSTALLED.

First Use

Clean the oven thoroughly with soapy water and rinse well. To remove the lateral frames from smooth walled ovens, proceed as shown in the figure. Operate the oven for about 30 minutes at maximum temperature to burn off all traces of grease which might otherwise create unpleasant smells when cooking.

Do not use rough abrasives or sharp metal scrapers to clean the glass door of the oven because they could scratch the surface and cause the glass to shatter.

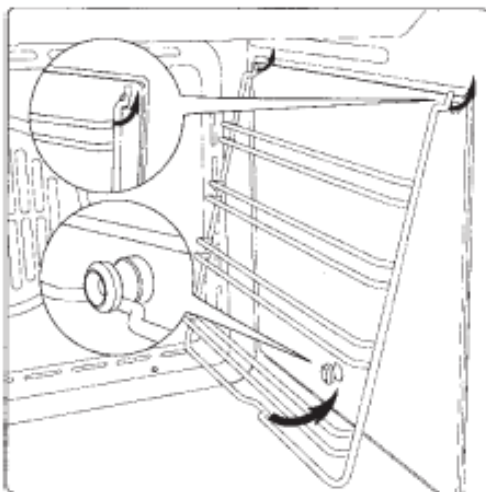

Important:

Do not use steam cleaners to clean the appliance.

As a safety precaution, before cleaning the oven, always disconnect the plug from the power socket or the power cable from the oven. Do not use acid or alkaline substances to clean the oven (lemon juice, vinegar, salt, tomatoes etc.). Do not use chlorine based products, acids or abrasive products to clean the painted surfaces of the oven.

SELF-CLEANING CATALYTIC PANELS

Our smooth walled ovens can be fitted with self-cleaning panels to cover the inside walls. These special panels are simply hooked on to the walls before the side frames are fitted. They are coated in a special, micro porous catalytic enamel which oxidises and gradually vaporises splashes of grease and oil at cooking temperatures above 200° C. If the oven is not clean after cooking fatty foods, operate the empty oven for 60 minutes (max.) at maximum temperature. Never wash or clean self-cleaning panels with abrasive, acid, or alkaline products.

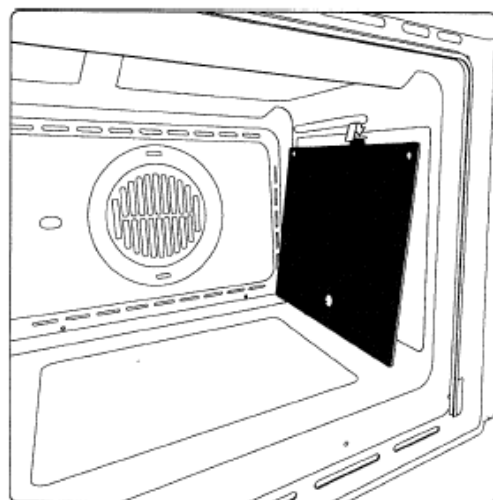

CATALYTIC LINERS ARE AVAILABLE TO PURCHASE AS AN ACCESSORY FROM ILVE SPARE PARTS - P: 1300 694 853

**SIDE LINERS - code 42105581 \$40ea (2 REQUIRED)
REAR LINER - code 42105083 \$60**

CONTROL PANEL FUNCTIONS

FUNCTION SYMBOLS ON THE SELECTOR

Oven light (stays on while oven is in use).



Bottom heating element. Thermostat setting from 50°C to MAX.



Top and bottom heating elements. Thermostat setting from 50°C to MAX.



Top and bottom heating elements with fan. Thermostat setting from 50°C to MAX.



Circular heating element with fan. Thermostat setting from 50°C to MAX.



Fan for defrosting. Thermostat setting at 0°C.



Bottom heating element with fan. Thermostat setting from 50°C to MAX.



Double top heating element with fan (large area grill). Thermostat setting from 50°C to 200°C.



Double top heating element (large area grill). Thermostat setting from 50°C to 200°C.



Top heating element with fan. Thermostat setting from 50°C to 200°C.



Top heating element (small, low power grill). Thermostat setting from 50°C to 200°C.



Bottom heating element +Circular heating element with fan. Thermostat setting from 50°C to MAX.



ATTENTION: Accessible parts may become very hot during use. Children should be kept at a distance.

Indicative table for positioning foods based on functions, temperatures and cooking times

F																						
°C	160-200	160-180	140-160	200-230	210-220	160-180	190	230-250	225-250	160-180	210-230	160-190	200-220	160-180	175-190	190-210	170-190					
	2-3	2	2	1-3	2	2-3	2-3	4-5	2	2	2	2	2-3	2	2	2	2	2	2	2	3	
	30'- 50'	20'- 40'	10'- 40'	10'- 20'	45'- 60'	45'- 60'	60'- 70'	14'-18'	120'- 150'	120'- 160'	90'- 120'	90'- 120'	50'- 60'	45'- 60'	60'- 70'	40'- 50'	40'- 50'					

INSTRUCTIONS FOR USE CONVENTIONAL COOKING

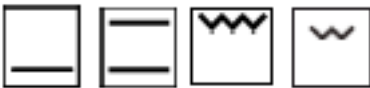

Conventional cooking uses top and bottom heat to cook a single dish. Place the food in the oven only once cooking temperature has been reached, i.e. when the heating indicator goes out. If you want to increase top or bottom temperature towards the end of the cooking cycle, set the temperature control to the right position. It is advisable to open the oven door as little as possible during cooking.

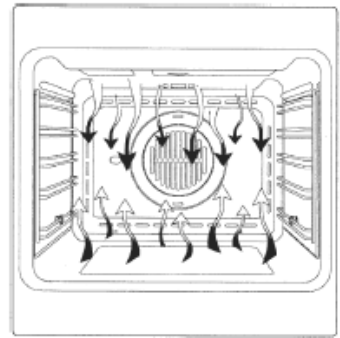

FAN COOKING



For this type of cooking a fan positioned at the back allows the circulation of hot air inside the oven, creating uniform heat. In this way cooking is more rapid than conventional cooking. It is a suitable method for cooking dishes on more than one shelf, especially when the food is of different types (fish, meat etc.)

DEFROSTING



By selecting one of the fan cooking functions and setting the thermostat to zero, the fan allows cold air to circulate inside the oven. In this way frozen food can be rapidly defrosted. It is not essential to pre-heat the oven, but you are advised to do so when cooking pastries.

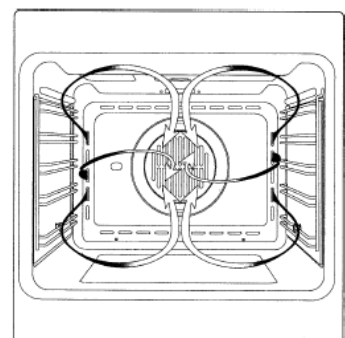

GRILL COOKING



Use the grill to grill or brown foods. Some ovens may be equipped with an electric motor, spit and skewers for turning on the spit. Place the shelf with the food to be cooked in the 1st or 2nd position from the top. Pre-heat the oven for 5 minutes. Turn the thermostat to a temperature between 50°C and 200°C.

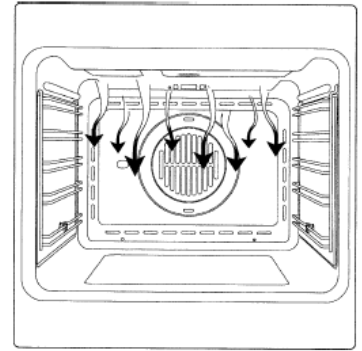

COOLING FAN (if supplied)

The fan is positioned on the upper part of the oven and create a circle of cooling air on the inside of the furniture and through the door of the oven. It is turned on when the temperature of the outer shell of the oven reaches 60°C. By switching on the oven with the thermostat at 200°C the fan starts working after approx. 10 min. It is turned off when the temperature of the outer shell of the oven descends under 60°C. By switching off the oven with the thermostat at 200°C the fan stops working after approx. 30 min.

THERMOSTAT

Use the thermostat to set the cooking temperature you need. The thermostat can be adjusted from 50° to 250° C.



0-11 HEAT REGULATOR

0-6 SELECTOR

Use these to adjust the heat in the cast iron or glass ceramic plates. Increase the setting from 0 to 6 or from 0 to 11 to raise the temperature.



ALARM TIMER

You can set this timer to sound a buzzer after 0 to 60 minutes of cooking. First turn the knob fully clock-wise, then turn it back to the desired alarm time.



COOKING TIMER

First, turn the cooking selector to the required cooking function, and the thermostat to the desired cooking temperature. Then, to set *end of cooking time*, turn the cooking timer to the right and to the desired time. First turn the knob fully clockwise, then turn it back to the desired alarm time. A buzzer sounds at the end of the timed cooking period, and the oven switches itself off. To set only the *start of cooking*, turn the cooking timer to the left to the

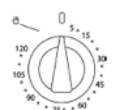

PROGRAMMING END OF COOKING TIME WITH THE ANALOGUE TIMER

Setting the clock

Push the knob out and turn it anticlockwise to set the clock. First, turn the cooking selector to the required cooking function, and the thermostat to the desired cooking temperature. Then, to set end of cooking time, turn the cooking timer to the end to the desired time. A buzzer sounds at the end of the timed cooking period, and the oven switches itself off. Push that timer knob in to silence the buzzer





To set only the start of cooking, leave the knob in the manual  position.



6 KEY ELECTRONIC TIMER

Setting the clock

Press the duration key  and the end of cooking  key simultaneously, then press the +/- keys to set time.

MANUAL OPERATION

To start cooking with out setting end of cooking time, press the manual  key

SETTING ONLY THE DURATION OF COOKING IN SEMI-AUTOMATIC MODE

To set the duration of cooking, press the duration key and press the +/- keys to set the duration of cooking. A buzzer sounds when the cooking period finishes, and the oven switches itself off. Turn the thermostat and selector knobs back to 0 position and press the manual key.

SETTING ONLY THE END OF COOKING TIME IN SEMI-AUTOMATIC MODE

To set the end of cooking time, press the end of cooking  key and press the +/- keys to

set the time at which you want the oven to switch off. A buzzer sounds when the clock reaches the set time, and the oven switches itself off. Turn the thermostat and selector knobs back to 0 position and press the manual key.

FULLY AUTOMATIC OPERATION

To set the end of cooking time, press the



the duration of cooking. Press the end of



duration key and press the +/- keys to set cooking key and press the +/- keys to set

the time at which you want the oven to switch off. When you finish setting these times, the AUTO symbol flashes and the buzzer sounds. Press any key to silence it.

ALARM TIMER

Press the alarm timer key and press the +/- keys to set the required duration of cooking. The buzzer sounds when the cooking time ends. Press any key to silence it.

PROGRAMMING ERRORS

You cannot program in a cooking period which starts earlier than the time displayed on the clock. If you try to do so, the buzzer sounds and the AUTO symbol flashes. Simply change the duration or cooking time to correct the error.

CANCELLING A COOKING PROGRAMME

To cancel a cooking programme, simply press the manual key.

REPLACING THE OVEN LIGHT IMPORTANT:

The oven light must have these precise features:

- a) it must be able to resist high temperatures (up to 300°C)
- b) power supply: see V/Hz indicated on data plate.
- c) power 25W.
- d) E 14 connection.

Before proceeding, disconnect the appliance from the power line to avoid the possibility of electric shock.

- to prevent damage, place a tea cloth in the oven-unscrew the glass cover of the light
- unscrew the old light bulb and replace it with the new one
- put back the glass cover and remove the tea cloth
- connect the appliance to the main electricity supply

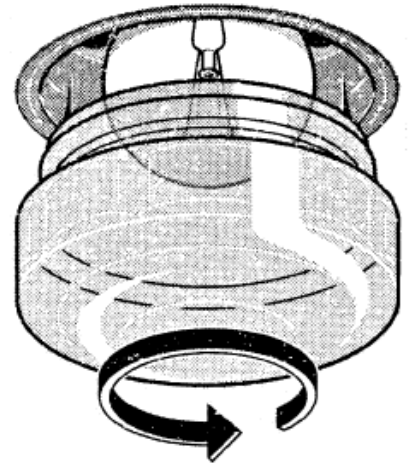

REMOVING THE OVEN DOOR

The oven door can be removed quickly and easily. To do so, proceed as follows:

- Open the door fully.
 - Lift the two levers shown in fig.
 - Close the door as far as the first stop (caused by the raised levers).
 - Lift the door upwards and outwards to remove it from its mountings.
- To replace fit the door, fit the hinges in their mountings and lower the two levers.

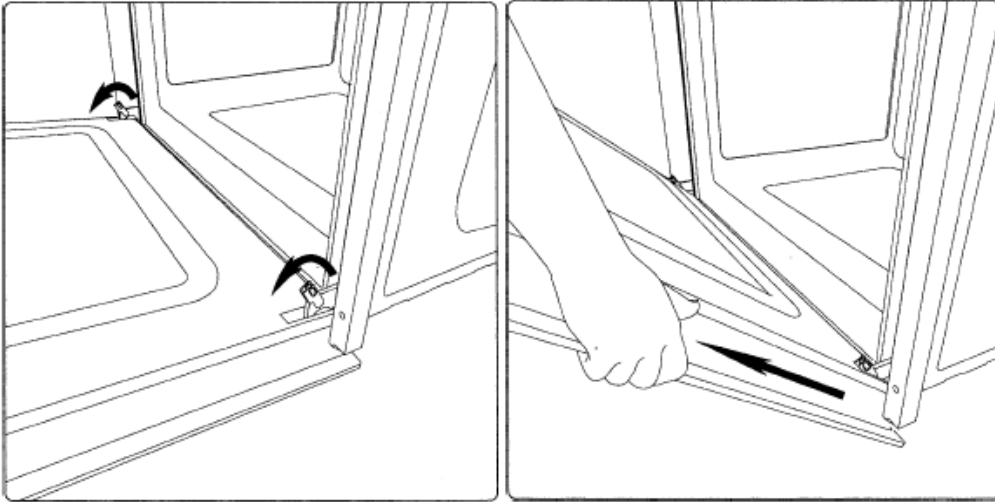

INSTALLATION INSTRUCTIONS

Flush fitting

The oven can be installed under a work top or in a cooking column. Figure shows the installation dimensions. Make sure that surrounding materials are heat resistant. Align the oven centrally with respect to the sidewalls of the units surrounding it and fix it in place with the screws and Allen screws provided.



Insert the bushings provided in the holes in the face.

Use the four screws provided to fasten the bushings to the cabinet, taking care not to over tighten and break the bushing.

See the accompanying instructions for combining the oven with multifunctional gas or gas-electric cookers.

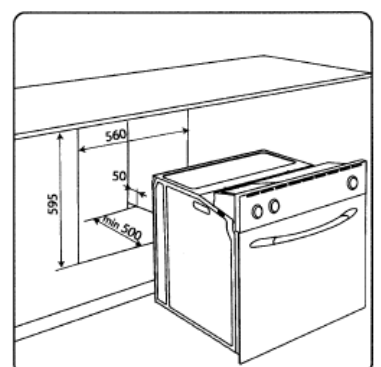
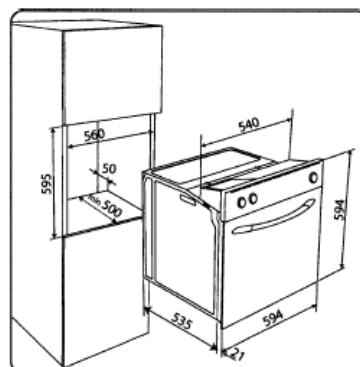

GAS OR ELECTRICAL CONNECTIONS

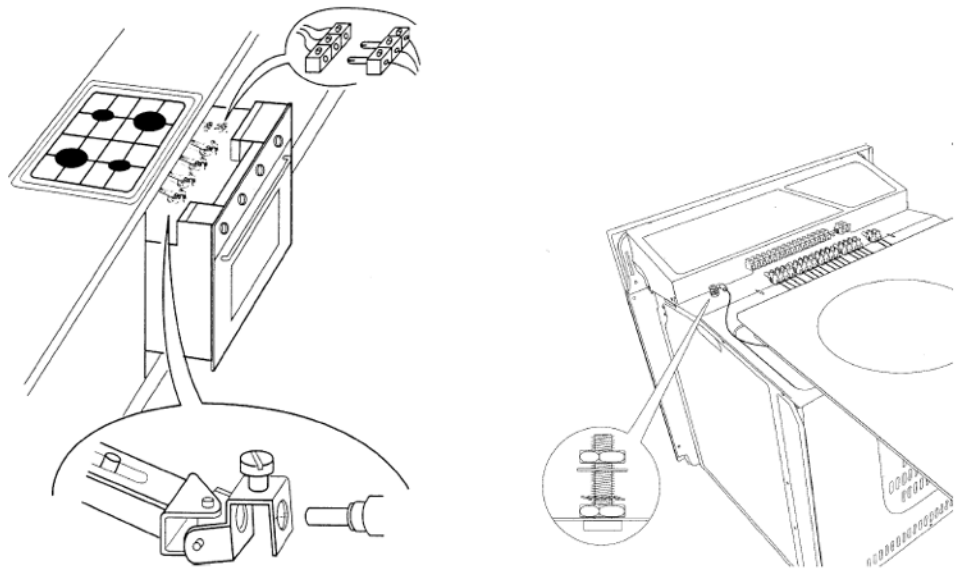

Before connecting the oven to the mains power supply, make sure that:

- The supply voltage corresponds to the specifications on the data plate on the front of the oven.
- The mains supply has an efficient earth (ground) connection complying with all applicable laws and regulations. Correct earth (grounding) is a legal requirement. The power cable should never reach a temperature 50°C above ambient temperature at any point along its length. If a fixed appliance is not provided with a power cable and plug, or some other device permitting it to be disconnected from the mains electricity supply, with a gap between the contacts big enough to guarantee class III over voltage protection, then such a device must be fitted to the power supply in compliance with the regulations governing electrical installations.

The omnipolar plug or switch must be easy to reach when the appliance is installed. The unit becomes very hot during use. Be careful not to touch the heating elements inside the oven. If the oven came with a meat probe, use only the probe recommended for this oven. The different cooking levels where grids and drip pans can be placed are shown in the table on page 5.

TIPI E DIAMETRO MINIMO DEI CAVI CABLE TYPES AND MINIMAL DIAMETERS TYPES ET DIAMÈTRE MINIMAUX DES CÂBLES	
SASO	
H05RR-F 3x1,5 mm ²	H05RR-F 3x2,5 mm ²
H05VV-F 3x1,5 mm ²	H05VV-F 3x2,5 mm ²
H05RN-F 3x1,5 mm ²	H05RN-F 3x2,5 mm ²
H05V2V2-F 3x1,5 mm ²	H05V2V2-F 3x2,5 mm ²

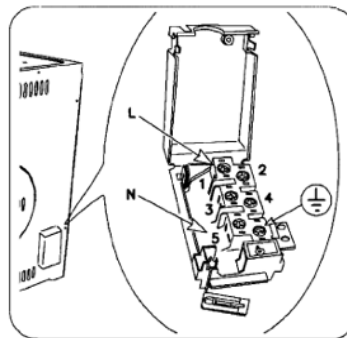

N.B. The manufacturer de-clines all responsibility for damage or injury if the above instructions and nor-mal safety precautions are not respected.

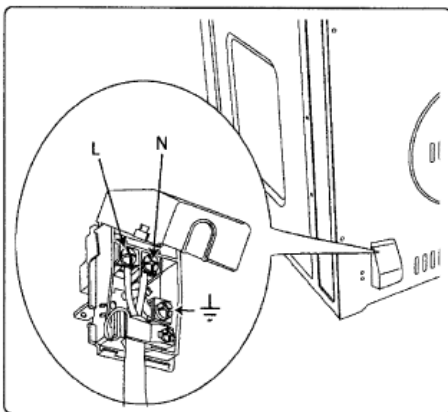

\sim 230V ● 1 2 3 4 5 ⊕ PE L R L N	230V \sim	*3 x 4 mm ²
\sim 230V 3 ● 1 2 3 4 5 ⊕ PE L R L S T L3	230V 3	*4 x 2,5 mm ²
\sim 400V 2N ● 1 2 3 4 5 ⊕ PE L R L S T N	400V 2N \sim	*4 x 2,5 mm ²
\sim 400V 3N ● 1 2 3 4 5 ⊕ PE L R L S T L3 N	400V 3N \sim	*5 x 1,5 mm ²

The contents of this manual are generic and not all the functions described may be available on your product.

The manufacturer declines all responsibility for possible inaccuracies contained in this manual, due to printing or copying errors. We reserve the right to make on our own products those changes to be considered necessary or useful, without jeopardising the essential characteristics.

Eurolinx Pty Limited A.B.N. 50 001 473 347
trading as ILVE ("ILVE")

Office:

48-50 Moore Street, Leichhardt N.S.W 2040
Post:

Locked Bag 3000, Annandale, N.S.W 2038
P: 1300 856 411

WARRANTY REGISTRATION

Your ongoing satisfaction with your ILVE product is important to us. We ask that you complete the enclosed Warranty Registration Card and return it to us so that we have a record of the ILVE products you purchased. Alternatively you can register on line (see registration card for details)

PRIVACY

ILVE respects your privacy and is committed to handling your personal information in accordance with the National Privacy Principles and the Privacy Act 1988 (Cth). A copy of the ILVE Privacy Policy is available at www.ilve.com.au. ILVE will not disclose any personal information set out in the Warranty Registration Card ("Personal Information") without your consent unless required by:

1. law;
2. any ILVE related company;
3. any service provider which provide services to ILVE or assist ILVE in providing services (including repair and warranty services) to customers. Our purpose in collecting the Personal Information is

to keep a record of the ILVE product purchased by you, in order to provide a better warranty service to you in the unlikely event that there is a problem with your ILVE product. ILVE may contact you at any one or more of the address, email address or telephone numbers set out in the Warranty Registration Card. Please contact ILVE on 1300 694 583 should you not wish to be contacted by ILVE.

WARRANTY

1. Warranty

ILVE warrants that each ILVE product will remain, for a period of twenty four (24) months computed from the date of purchase of the ILVE product, free from defects arising in the manufacture of the ILVE product ("Warranty"). Except for consumer guarantees set out in the Competition and Consumer Act 2010 (Cth) ("Act"), ILVE does not make any further warranties or representations in relation to ILVE products.

2. What is not Covered by the Warranty.

The Warranty does not apply if an ILVE product is defective by a factor other than a defect arising in the manufacture of the ILVE product, including but not limited to:

- (a) damage through misuse (including failure to maintain, service or use with proper care), neglect, accident or ordinary wear and tear (including deterioration of parts and accessories and glass breakage);
- (b) use for purpose for which the ILVE product was not sold or designed;
- (c) use or installation which is not in accordance with any specified instructions for use or installation;
- (d) use or operation after a defect has occurred or been discovered;
- (e) damage through freight, transportation or handling in transit (other than when ILVE is responsible);
- (f) damage through exposure to chemicals, dusts, residues, excessive voltage, heat, atmospheric conditions or other forces or environmental factors outside the control or ILVE;
- (g) repair, modification or tampering by the purchaser or any person other than ILVE, an employee of ILVE or an authorised ILVE service contractor;
- (h) use of parts, components or accessories which have not been supplied or specifically approved by ILVE.
- (i) damage to surface coatings caused by cleaning or maintenance using products not recommended in the ILVE product handbook provided to the purchaser upon purchase of the ILVE product;
- (j) damage to the base of an electric oven due to items having been placed on the base of the oven cavity or covering the base, such as aluminium foil (this impedes the transfer of heat from the element to the oven cavity and can result in irreparable damage); or
- (k) damages, dents or other cosmetic imperfections not affecting the performance of the ILVE in respect of an ILVE product purchased as a "factory second" or from display.

The Warranty does not extend to light globes used in ILVE products.

Customers must retain proof of purchase in order to be eligible to make a warranty claim in respect of an ILVE product.

6. Claiming under the Warranty

Customers will bear the cost of claiming under this Warranty unless ILVE determines the expenses are reasonable, in which case the customer must claim those expenses by providing written evidence of each expense to ILVE at the address on the Warranty Registration Card.

3. Domestic Use

Each ILVE product is made for domestic use. This Warranty may not extend to ILVE products used for commercial purposes; under those circumstances the warranty period is limited to 3 months.

4. Time for Claim under the Warranty

You must make any claim under this Warranty within twenty eight (28) days after the occurrence of an event which gives rise to a claim pursuant to the Warranty, by booking a service call on the telephone number below.

5. Proof of Purchase

Customers must retain proof of purchase in order to be eligible to make a warranty claim in respect of an ILVE product.

6. Claiming under the Warranty

Customers will bear the cost of claiming under this Warranty unless ILVE determines the expenses are reasonable, in which case the customer must claim those expenses by providing written evidence of each expense to ILVE at the address on the Warranty Registration Card.

7. Statutory Rights

(a) These terms and conditions do not affect your statutory rights.

(b) The limitations on the Warranty set out in this document do not exclude or limit the application of the

consumer guarantees set out in the Act or any other

equivalent or corresponding legislation in the relevant

jurisdiction where to do so would:

(i) contravene the law of the relevant jurisdiction; or

(ii) cause any part of the Warranty to be void.

(c) ILVE excludes indirect or consequential loss of any kind (including, without limitation, loss of use of the

ILVE product) and (other than expressly provided for in these terms and conditions) subject to all terms,

conditions and warranties implied by custom, the general law, the Act or other statute.

IMPORTANT!

All warranty service calls must be booked via the customer care department. The team can be contacted on 1 300 85 64 11 option 1 or customercare@eurolinx.com.au

Service is delivered through a network of Service Agents. If the Appliance is located outside our normal Service Area of our agents you, the Customer will need to bear the cost of travel outside that area.

If you are unable to provide proof of purchase, the fault is not covered under warranty or the product is found to be working to specification you may be required to bear the full cost of the service visit

01072016

Warranty Card tear off

WARRANTY REGISTRATION CARD
01012013

Please complete and send to ILVE at: REPLY PAID 83617
LEICHHARDT NSW 2040

Last Name:		First Name:	
Address:			
State:	Postcode:	Email:	
Home Phone:		Mobile:	
Purchase Date: / /		(Please attach proof of purchase to validate warranty)	

MODEL NUMBER	SERIAL NUMBER (if you cannot locate the serial number please call ILVE on 1300 85 64 11)
1	
2	
3	
4	

01072016

Australia National Telephone Number 1300 MYILVE (694 583) New Zealand Telephone Number 0508 458 369
ILVE showrooms are open daily from 9am-5pm and Saturdays 10am-4pm

ilve.com.au

NSW & ACT (Head Office)

48-50 Moore Street
Leichhardt
F 02 8569 4699

VIC & SA

1211 Toorak Road
Camberwell
F 03 9809 2155

QLD

1/42 Cavendish Road
Coorparoo
F 07 3397 0850

WA & NT

Unit 10/55 Howe Street
Osborne Park
F 08 9201 9188

TAS (Crisp Ikin)

3 Pear Avenue
Derwent Park, 7009
P 03 6272 7386

New Zealand

PO Box 11.160
Sockburn Christchurch
F 03 344 5906